



Plug-and-Play Class 2 60 Watt LED Driver

The SLD 60 is a highly reliable and installation ready, class 2, switched-mode, AC/DC LED driver, with 90-264VAC input, rated for maximum output of 60 Watts. This driver offers user adjustable output voltage/current trim-pots, and is the industry's only LED power supply, with built-in wiring compartments. This allows all wiring to be done inside the unit, without the need for external junction boxes, which saves on cost and installation time. All units are fully potted and are rated IP 65, making them suitable for a wide range of LED lighting and signage applications.

SLD60

Signage / Architectural LED Drivers

US Patent Numbers: 7,154,755 & 7,738,253



Model Selection Key

SLD60-ABBV-FC

- With Trim Pots
- Nominal Output Voltage
- Number of Output Channel(s)
- Series Name

Features

- Plug-and-Play Conduit Entry Ports and Wiring Compartments eliminate need for external junction boxes.
- Universal Input 90-264 V_{AC}
- User Adjustable Output Voltage and Current
- UL/cUL/FCC/CE/EMC
- Built in Over Current, Over Voltage, and Short Circuit Protection
- Low peak/noise current
- IP 65
- Remote Dimming Options
- 3 years Warranty

Applications

- Architectural Lighting
- Effect & Contour Lighting
- Office General Illumination
- Residential Lighting
- Signage
- Strip Lighting
- Horticultural Lighting

Model Number	Input Voltage Range (V _{AC})	Channel(s) Output	CC mode						CV Mode				Max Output Power (per Channel) (W)	Total Output Power (W)
			Rated Current (per Channel) (A)	Compliance (LED) Voltage (V _{DC})		Current Pot C Adjustable Range (All Channels) (A)		Preset Vout (V _{DC})	Load Range (per Channel) (A)		Voltage Pot Adjustable Range (V _{DC})			
				min	max	min	max		min	max	min	max		
SLD 60-110V-FC	90-264	1	5.0	5.0	10.0	0.50	5.00	10	0	5.00	7.5	11.0	50	50
SLD 60-112V-FC	90-264	1	5.0	6.0	12.0	0.50	5.00	12	0	5.00	9.0	13.2	60	60
SLD60-115V-FC	90-264	1	4.0	7.5	15.0	0.40	4.00	15	0	4.00	11.3	16.5	60	60
SLD 60-118V-FC	90-264	1	3.3	9.0	18.0	0.33	3.33	18	0	3.33	13.5	19.8	60	60
SLD 60-121V-FC	90-264	1	2.9	10.5	21.0	0.29	2.86	21	0	2.86	15.8	23.1	60	60
SLD 60-124V-FC	90-264	1	2.5	12.0	24.0	0.25	2.50	24	0	2.50	18.0	26.4	60	60
SLD 60-148V-FC	90-264	1	1.3	24.0	48.0	0.13	1.25	48	0	1.25	36.0	52.8	60	60

FC = Patented, easy install enclosure with integral wiring compartments.

Input Specification

Voltage Range	Frequency Range	Max Inrush Current
90-264 V _{AC} (NOM: 120/240 V _{AC})	47-63 Hz	30A@230 V _{AC} input, 25°C, cold start-up

Output Specification

Max Power	60 W	Transient Response	4 mS, full load to half load, 100 V _{AC} Input
Load Regulation	+/- 1% Max	Short Circuit Protection	Hiccup-Mode, Auto-Recovery upon removal of short circuit condition.
Efficiency	80% typ.	Constant Voltage (CV) Mode Load Regulation	+/- 3% Max (Voltage Setting Adjustable via on-board pot: +5%/-30%)
Noise/Ripple	1.5% of Rated Output Voltage*	Constant-Current (CC) Mode Regulation	+/- 2% Max (Current Setting Adjustable via on-board pot: +5%/-90%)
Start-up Time	2 sec. Typical	Over Voltage Protection	132% Max
Hold-up Time	16mS @ full load, 100V _{AC} input	Over Current Protection	Constant-current limiting

* All noise measurements made at the output terminals, connected to a 20MHz low pass filter.

Environmental Specifications

MTBF	Cooling	Operating Temp	Storage Temp	Relative Humidity
55,000 hours (Full load @ 25°C Ambient, Based on MIL-217F)	Convection	-30°C to 60°C (Full load)	-40°C to 85°C	5% - 95 %

Compliance / Safety

EMI/RFI:	CISPR-22 Class B FCC part 15 Class B EN 55015
Safety Standards:	UL/cUL 1012/1585 UL 1310 Class 2, UL 48 CE
Weatherability:	EN60529 IP 65

Mechanical

Material:

NEMA 3 Design with patented AC and DC Wiring compartments, fully potted PCB.

Remote Dimming Options

Dimming Types	Dimming Control
1. PWM-1kHz, 1-100%	• 1-10V DC
2. Constant Current, 10-100%	• Potentiometer
3. Output Voltage, 75-100%	• Serial Comm. (2-wire)
4. Compatible with SLD DIM	• Wireless Remote

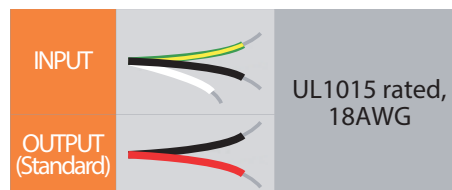

Performance Curves

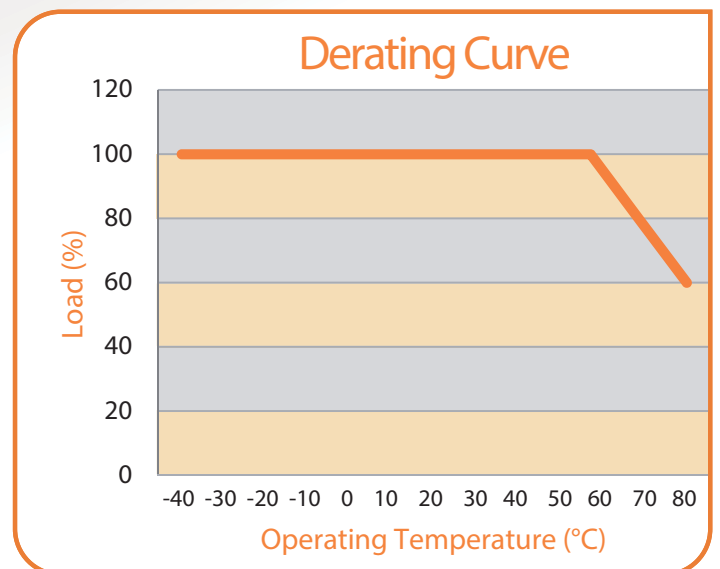
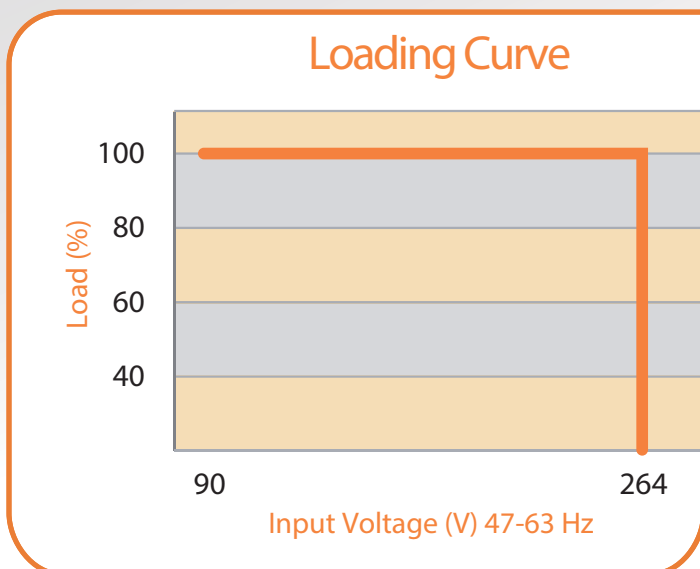
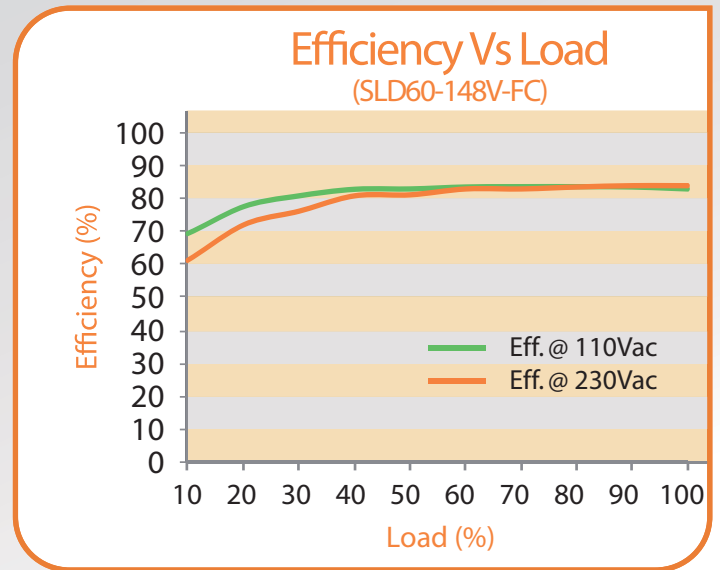
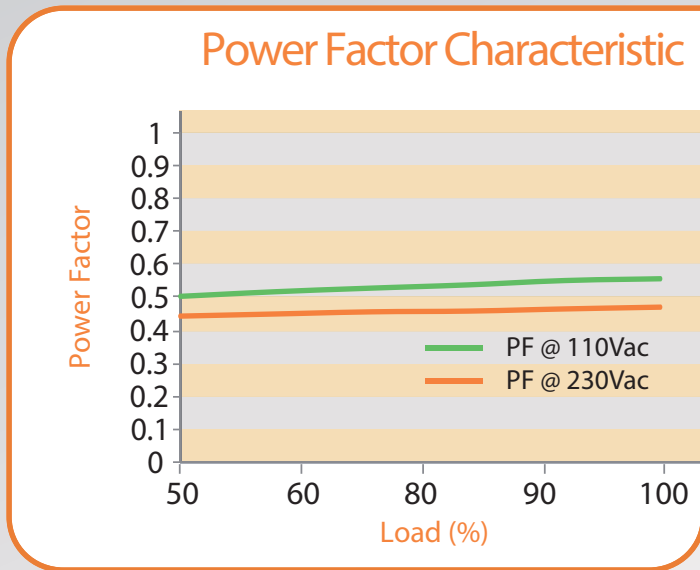

Mechanical Diagrams

Single Channel Output Model

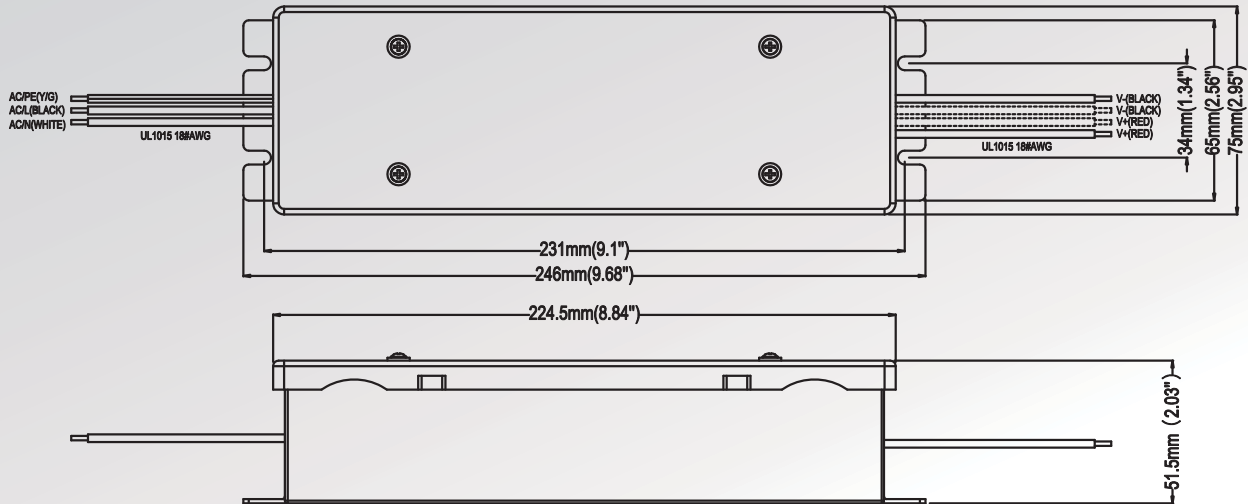

Packing Information

Weight: 0.892 kg/pcs, 11.3 kg/carton
 12 pcs/carton; L340xW285xH210 (mm)
 US Patent Numbers: 7,154,755 & 7,738,253

Configuration Arrays

Single Channel Output Model

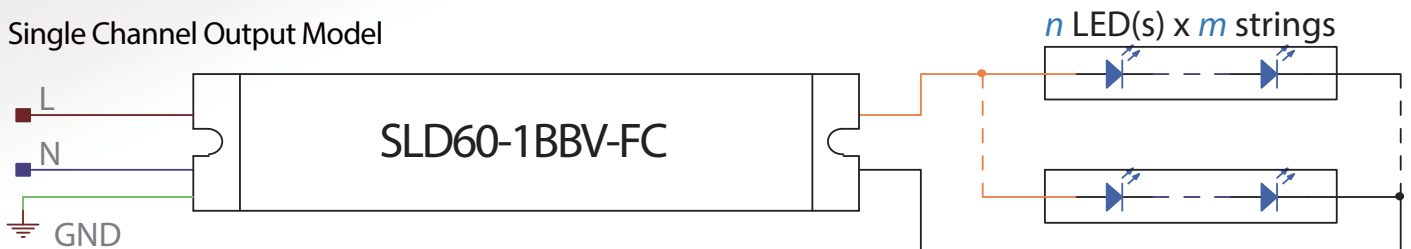

Model	CC mode LED Voltage Range (V)	Recommended n LED(s) per String *	Current POT Adjust Range (A)	LED Current per String
SLD60-110V-FC	5 - 10	2 - 3	0.5 - 5	$= \frac{I_{out}}{m \text{ Strings}}$
SLD60-112V-FC	6 - 12	2 - 3	0.5 - 5	
SLD 60-115V-FC	7.5 - 15	2 - 4	0.4 - 4	
SLD 60-118V-FC	9 - 18	3 - 5	0.33 - 3.33	
SLD 60-121V-FC	10.5 - 21	3 - 6	0.29 - 2.86	
SLD 60-124V-FC	12 - 24	4 - 7	0.25 - 2.5	
SLD 60-148V-FC	24 - 48	7 - 14	0.13 - 1.25	

* LED Vf range: 2.7-3.6V

Information furnished is believed to be accurate and reliable. However, GRE Alpha assumes no responsibility for the consequences of use of such information nor for any infringement of patents or other rights of third parties which may result from its use. No license is granted by implication or otherwise under any patent or patent rights of GRE Alpha. Specifications mentioned in this publication are subject to change without notice. This publication supersedes and replaces all information previously supplied.

The GRE Alpha logo is a registered trademark of GRE Alpha Electronics Ltd.
 All other names are the property of their respective owners